



Electronic room thermostat  
**IB – Therm 203**  
for ventilation support, recuperators  
or two-pipes fan coils

PRODUCT IS CE MARKED **CE**

AND WAS PRODUCED IN ACCORDANCE WITH ISO 9001 STANDARD

„INSBUD”  
ul. Niepodległości 16a  
32-300 Olkusz  
sales department: +48 (32) 626 18 00  
sales department: +48 (32) 626 18 18  
technical department: +48 (32) 626 18 07  
technical department: +48 (32) 626 18 08  
fax: +48 (32) 626 18 19  
e-mail: insbud@insbud.net



**WWW.INSBUD.NET**

InsBud company supports policy of development. The right to making changes and improvements in products and manuals without prior notice reserved!

The contents of this manual - the text and graphics are owned by InsBud company or its subcontractors. It is legally protected.

# Contents











## IB-THERM 203

General Information _____	4
Features _____	4
Principle of Operation _____	4
Technical Data _____	4
Scope of Delivery _____	4
Structure _____	5
Structure of Outputs _____	6
Exemplary Connection _____	7
Warranty _____	8

## GENERAL INFORMATION

**IB-Therm 203** room thermostat is designed to control valves, air dampers and heaters, fan coils and other heating appliances. **IB-Therm 203** thermostat allows to control process of heating, cooling and ventilation comfortably in the each type of buildings. It allows to save energy costs, contributing to protect our environment.

## FEATURES

-  Esthetic and traditional design
-  Easy and intuitive operating
-  Sensor with a negative temperature coefficient (NTC)
-  Available modes:
  - » heating
  - » cooling
-  Fan speed:
  - » low
  - » medium
  - » high
-  ON/OFF switch
-  Ability to precise room temperature setting, according to needs
-  Dedicated for four-pipes fan-coils.
-  Standard mounting dimensions
-  Surface mounting

## PRINCIPLE OF OPERATION











Thermostat measures the temperature by built-in sensor. The knob is used to set the desired temperature (switching threshold).

In the heating mode output device is turned on when the real temperature is lower than the desired temperature.



In the cooling mode output device is turned on when the real temperature is higher than the desired temperature.

Ventilation speed switch allows to set ventilation's efficiency (fan coil gear, fan gear).

## TECHNICAL DATA

	Energy consumption:	< 2 W
	Setting range:	10 ÷ 30 °C
	Hysteresis:	1 °C
	Accuracy:	1 °C
	Maximum load:	400 W
	Casing:	ABS
	Protection rating:	IP20
	Storage temperature:	-20 ÷ 60 °C
	Operating temperature:	0 ÷ 60 °C
	Control:	electronic
	Power supply:	230V AC or 24V AC/DC

## SCOPE OF DELIVERY



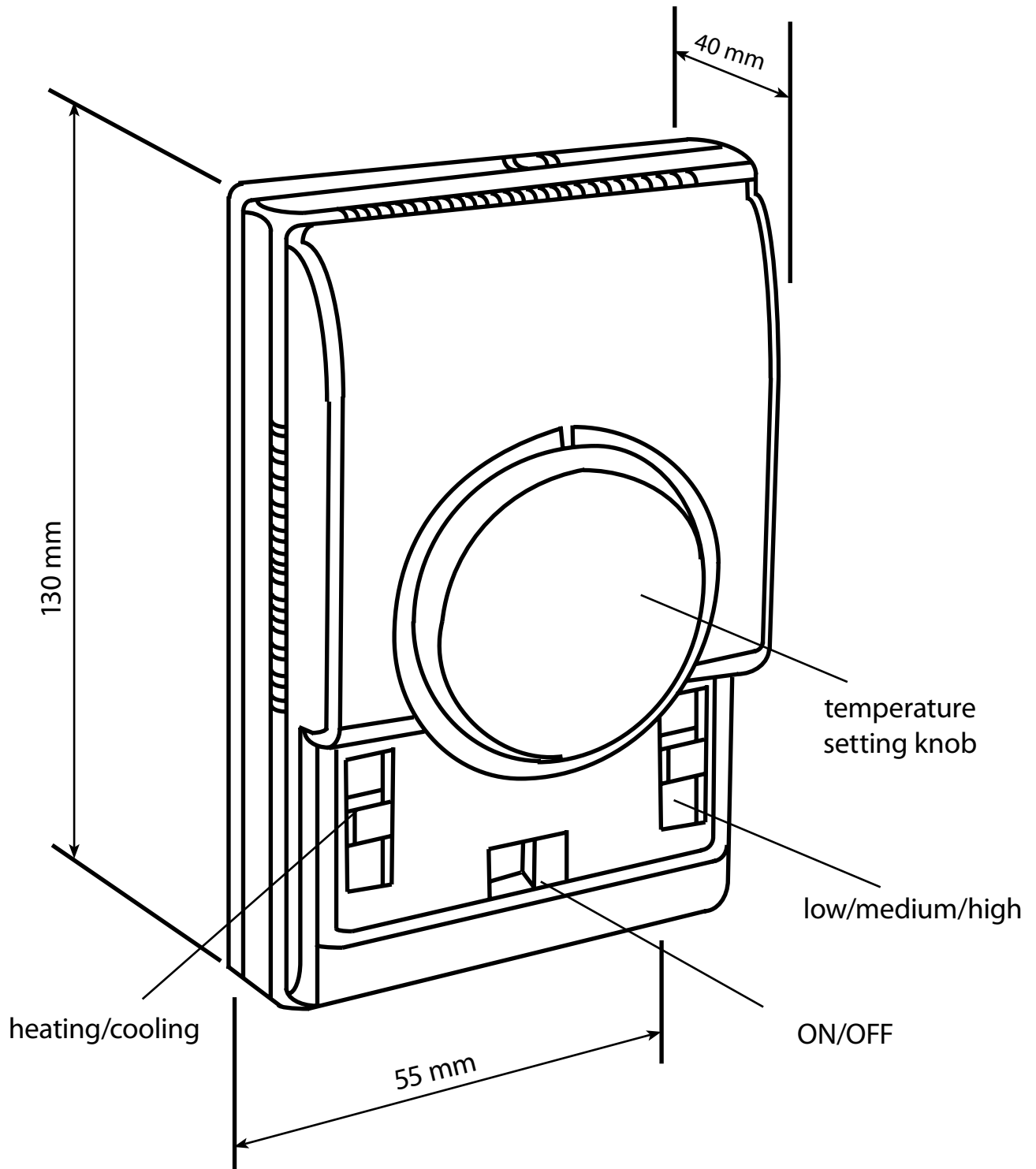

-  1x **IB-Therm 203** thermostat
-  1x Operating manual

Thermostats powered from 230V mains voltage are delivered implicitly. Also thermostats powered from 24V voltage source can be delivered (the same model for AC and DC voltage) if ordered. If you want to buy 24V thermostat, please indicate it in the order.

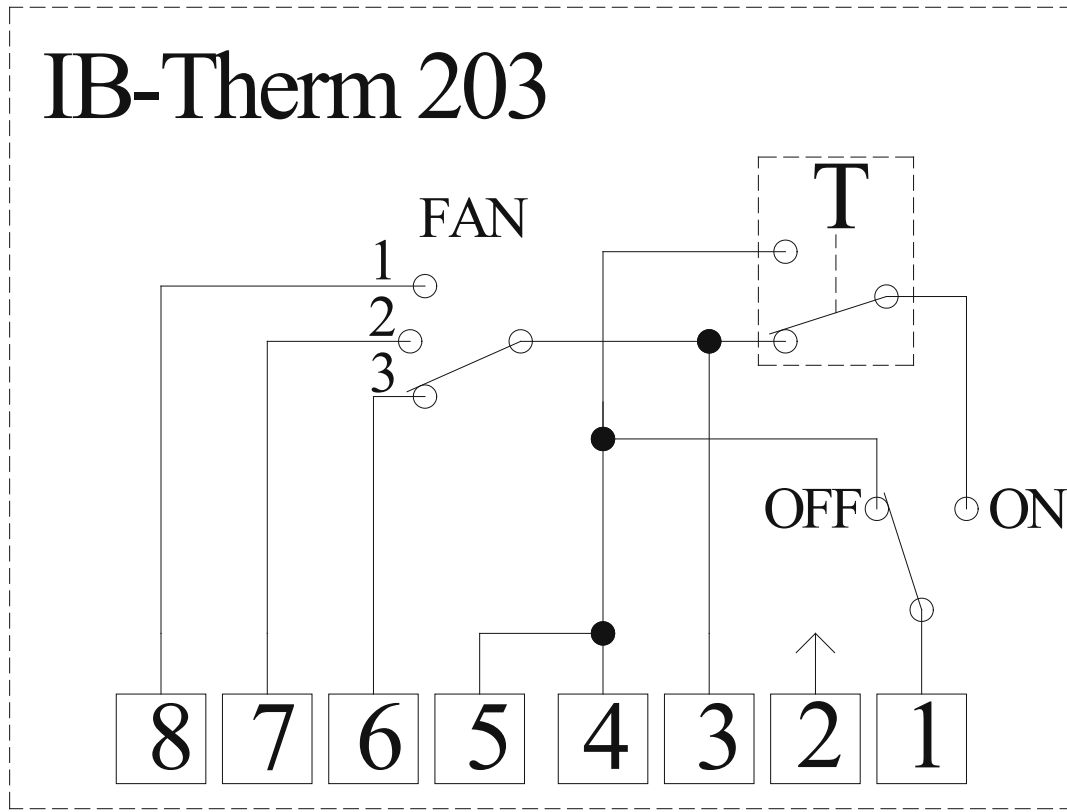

## Simplified diagram of outputs:



-  **1, 2** - power (depending on the model: 230V AC or 24V AC/DC);
-  **3** - this output is short to the input no. 1 when there is request to perform heating/cooling process and the thermostat is turned on (ON);
-  **4, 5** - these outputs are short to the input no. 1 when there is no request to perform heating/cooling process or when the thermostat is turned off (OFF);
-  **6** - output of gear 3. It is short to the input no. 1 when following requirements are simultaneously met: the thermostat is turned on (ON), there is request to heat/cool and 'FAN' switch is in the position '3';
-  **7** - output of gear 2. It is short to the input no. 1 when following requirements are simultaneously met: the thermostat is turned on (ON), there is request to

-  **8** - output of gear 1. It is short to the input no. 1 when following requirements are simultaneously met: the thermostat is turned on (ON), there is request to heat/cool and 'FAN' switch is in the position '1';

 Changing between heating and cooling modes only inverts the logical process. Outputs for connecting the output device are the same (3 - process is being performed, 4 - process is not being performed) for heating and cooling. Independent outputs for heating and cooling are implemented in **IB-Therm 203S** thermostat for four-pipes fan coils.

## EXEMPLARY CONNECTION

Following picture shows the exemplary wiring of „230V“ model:

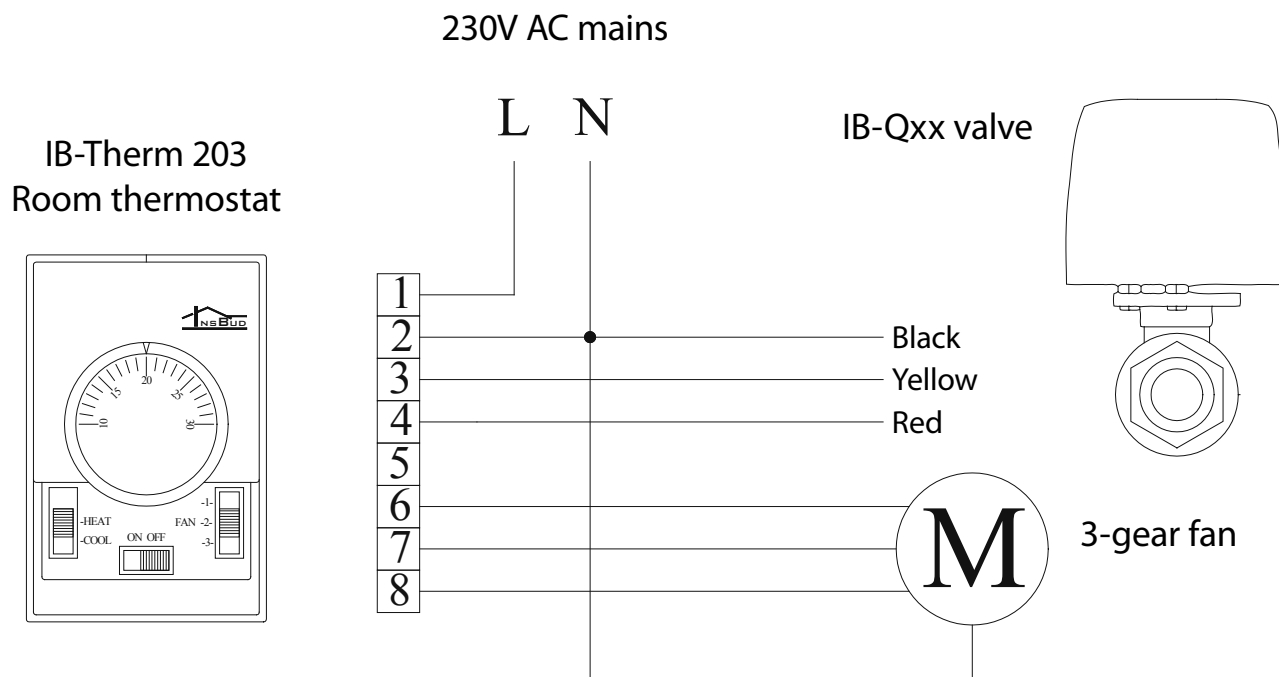

In this example, **IB-Therm 203** thermostat controls the two-pipes fan coil. Fan coil function (cooling or heating) is determined in advance and the same operational mode (heating or cooling) must be selected in the thermostat.

### In the heating mode:

When the thermostat is turned on and the real temperature is lower than the desired temperature, a valve is open (230V phase is in the yellow wire) and fan works at chosen speed.











When the thermostat is turned off or the real temperature is higher than the desired temperature, a valve is closed (230V phase is in the red wire) and fan is turned off.

### In the cooling mode:





When the thermostat is turned on and the real temperature is higher than the desired temperature, a valve is open (phase is in the yellow wire) and fan works at chosen speed.

When the thermostat is turned off or the real temperature is lower than the desired temperature, a valve is closed (phase is in the red wire) and fan is turned off.

## WARRANTY

-  Warranty is granted on 24 months from the date of purchase of goods.
-  Any defect disclosed during the warranty period will be removed within 21 working days, from the date of adoption of goods for service.
-  In case of necessity of import goods or components from abroad, repair time is extended by the time needed to bring them.
-  Customer provides product to service at his own cost. If the product is shipped at the expense of the service, it will not be received.
-  At time repair service has no obligation to provide substitute product.
-  Warranty repair will be made upon presentation of properly and legibly filled your warranty card, signed by guarantor and with sales document.
-  Warranty covers only defects arising from causes inherent in goods. Damage resulting from external causes such as: mechanical damage, pollution, flooding, weather, improper installation or improper wiring and operations. Warranty does not apply in case unauthorized repair by customer, changes in software (firmware) and device formatting.
-  Due to the natural consumption of consumables, some of them are not covered by warranty (for example: cables, battery, loader, micro contacts, buttons).
-  In the event of unjustified claim for warranty repair, all additional cost are on customer's side.
-  Service has right to refuse to perform warranty repairs for following: differences between documents and goods marks, make repairs on their own by customer, changes in product construction without authorization.

## WARRANTY

-  Warranty repair refusal is equivalent to loss your warranty.
-  If it is not possible to test product before its purchase (distance selling), it is possible to return goods within 10 days. Returned goods cannot bear signs of exploitation, it must contain all elements with which it was delivered.
-  In the case of return of purchased goods all shipping costs are on buyer's side. For shipment please enclose purchase document and give precise details of the buyer with account number on which will be refunded an amount equal to the value of the returned goods, no later than 21 days from the date of delivery of the goods. This amount is reduced by shipping costs if these costs were incurred by the seller. Delivery of copy of document correction is necessary to a refund. Before return of goods please contact with seller.
-  Warranty terms may be changed by local InsBud company partner.

„INSBUD”

ul. Niepodległości 16a

32-300 Olkusz

sales department: +48 (32) 626 18 00

sales department: +48 (32) 626 18 18

technical department: +48 (32) 626 18 07

technical department: +48 (32) 626 18 08

fax: +48 (32) 626 18 19

e-mail: [insbud@insbud.net](mailto:insbud@insbud.net)